

### YÜKLEME TABLOSU LOADING TABLE

28,4 ton daraya göre  
(According to 28.4 tonnes tare)

	A	B	C	D
S	67,6	79,6	94,6	106,6
SS	67,6	79,6	91,6	

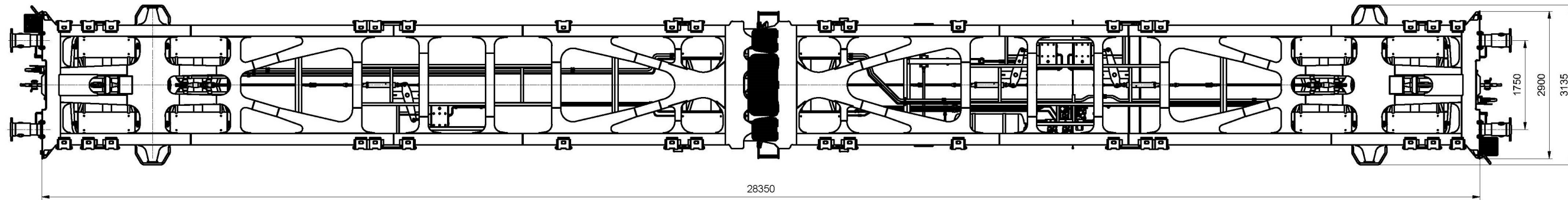

<b>DARA</b> Tare	Vagon Tipi Wagon Type	Sggmrss 90'
	WABTEC MZT Fren sistemi ile With the WABTEC MZT Brake System	≈ 28.400 Kg
<b>BOJİ ÖZELLİKLERİ</b> Bogie Features	Boji Tipi Bogie Type	Y25Ls(s)1-K
	Dingil Yüğü Axle Load	22 500 Kg
	Ray Açıklığı Railway Clearance	1 435 mm
	Tekerlek Tipi ve Çapı Wheelset Type and Dia.	Monoblok / Ø920
	Dingil Eksenleri Arası Distance Between axes	1 800 mm
<b>TAMPON</b> Buffer	Tampon Buffer	According to UIC 526-1 EN 15551+A1 Category A
	Tampon Tipi Buffer Type	Cat. A with polymer pads,
	Tampon Siası Buffer Stroke	105 mm

<b>CER</b> Drawgear	Cer Tertibatı Tipi Drawgear Type	According to UIC 520/With the polymer pads / 1500 kN
	Çekme Kancası Coupler Hook	According to UIC 520 1500 kN
	Koşum Takımı Screw Coupler	According to UIC 520 1350 kN
<b>FREN SİSTEMİ</b> Brake System	Fren Tipi Brake Type	SS Klasik Fren Sist SS C onventional System
	Sabo Tipi Brake Shoes Type	Jurid816M - Cosid 810 Jurid816M - Cosit 810
	Ei Fren Park Brake	Vagon Üzerinde Wagon mounted
	20 t dingil yükünde Max. Hızı Max. speed at an axle load 20 t	120 km/h
	22.5 t dingil yükünde Max. Hızı Max. speed at an axle load 22.5 t	100 km/h
<b>DiĞER</b> ÖZELLİKLER Other Features	Kurp Yarıçapı Curve Radius	75 m
	Yükleme Yüksekliği Loading Height	1 155 mm
	Güvenlik Pimi Sayısı Number of ct. Spigots	24

<b>YÜKLEME KAPASİTESİ</b> LOADING CAPACITY
20', 30', 40', 45'
Konteynerler farklı kombinasyonlarda
20', 30', 40', 45' Container. Different Combinations

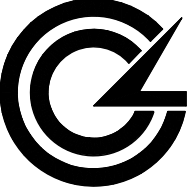
**GÖKYAPI**  
 SAN. ve TİC. A.Ş.

**Sggmrss 90' Vagon Karakteristiği**  
Sggmrss 90' Wagon Characteristics