

Drawing of bogie frame	GY - B.01.04.00.00.00
Gauge	1 435 mm
Wheel base	1 800 mm
Tare weight :Without hand brake / with hand brake	3900± %3 kg / 3935 ± %3kg
Height of Pivot center from top of the rail at 20 t wagon weight	925 mm (+2/-4)
Size of transverse clearances in axle guide stays	2 x 10 mm
Specific bogie suspension for the axle load	Up to 6,63 t = 2,45 mm/t Above 6,63 t = 0,93 mm/t
Maximum running speed	120 km/h
Maximum axle load	22,5 t
Wheel diameter max/min	Ø 920 and Ø 840 mm
Range of outdoor air temperatures	-25 °C to +40°C
Axle type	BA 002
Wheels type	BA 004 - 314 - 318
Axle roller bearing	WJ/WJP 130x240
Axle box type	BA 182
Maximum cant deficiency	130 mm
Range of distances between bogie pivot or range of wheel base of two axle unit	6.5 m - 20 m
Maximum height of centre of gravity of empty unit	1500 mm
Rail inclination	1:20 , 1: 30 , 1:40
Minimum tare of the unit	4.0 t/axle
Maximum mass distribution coefficient for empty units	0,55
Maximum moment of inertia around vertical axis	5160 kgm ²

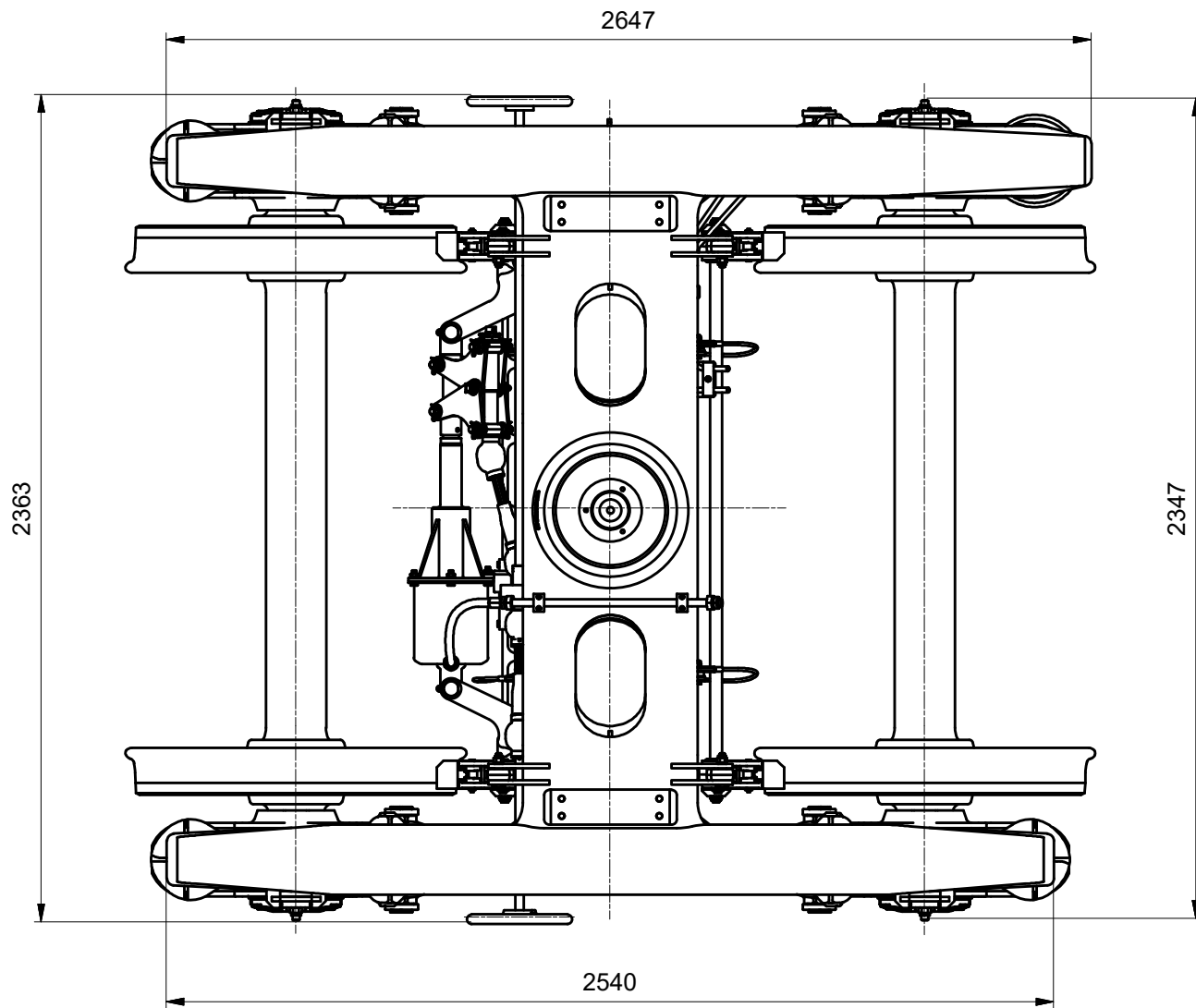

NOT1 : Tare weight was weighed with the BA 004 wheel set. This weight varies according to the type of wheel set.
NOT2 : Max speed is regarding to brake.

Genel Toleranslar General Tolerances

Isıl Kesme için TS EN ISO 9013-331 tolerans tablosu geçerlidir.

For thermal cutting use TS EN ISO 9013-331 table

Bükme için DIN 6935-tb2/tb4 tolerans tablosu geçerlidir.

For bending use DIN 6935-tb2/tb4 table

Talaşlı imalat için TS 1980-1 EN 22768 tolerans tablosu geçerlidir.

For machining use ISO 2768-mK table

Kaynaklı birleştirmelerde TS 13920-BF tolerans tablosu geçerlidir.

For welding use TS 13920-BF table

Tarih Date 31.12.2018

Onay Approved Nurettin YILDIRIM

Resim Designed Suat SAYIM

Tarih Date Değişiklikler Changes Kontrol Prepared Salih YİĞİT



H Tipi Boji (Komple)
(MZT Wabtec Frenli)

GY-B.01.01.00.00.00-A

Ölçek Scale	Ağırlık Weight (Kg)	Tip Type
1:20		Y25Lsdi-KC1

Sayfa No
Page No
01
Topl. Sayfa
Total Pages
01

